

Review and understand complete guide before beginning installation. This guide has been prepared as suggested details to particular design conditions. Each condition has certain limitations to performance, aesthetics or economics. Professionals qualified to assess this information for a specific project, should determine that the selection and installation are made to their requirements. ATAS **cannot** assume any responsibility for the actual selection and/or installation of materials. The panels, flashings and trim shown in this guide are illustrated over solid and plumb substrate. It is assumed that the structure has been designed and prepared in accordance with local building codes.

Installation Guide

The Dutch Seam roof panel, with integral seam, is available in three widths with seam spacing of 11", 15", and 19-1/4" o.c. The panels are roll-formed from 16 oz. copper, .032 and .040 aluminum and 24 ga. G90 galvanized steel, smooth or stucco embossed, with or without stiffening ribs. 22 ga. G90 steel is available, subject to minimum quantity. The material has a KYNAR 500® or HYLAR 5000® quality finish, in 31 standard colors. The minimum panel length is 2'-0", the maximum is determined by shipping considerations. Minimum recommended pitch is 2:12 depending upon geographical location and/or roof geometry..

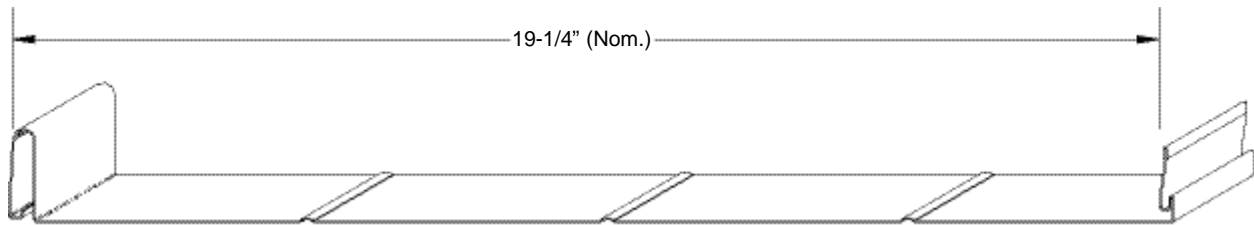

MRD194

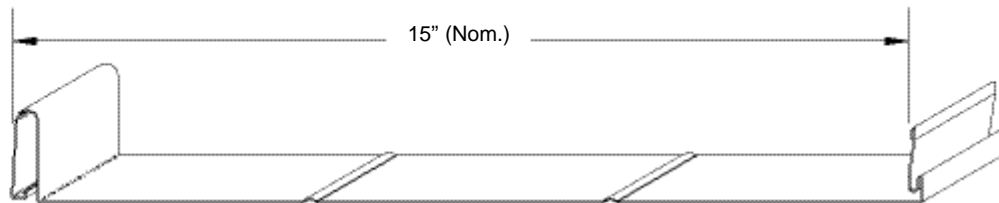

MRD150

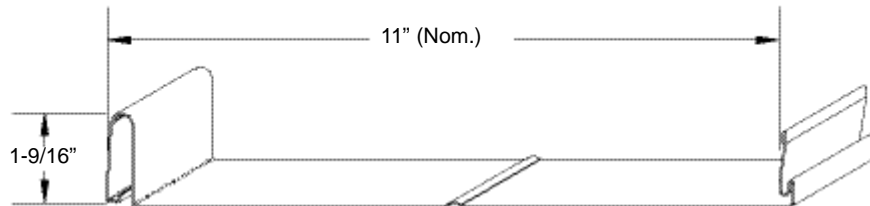

MRD110

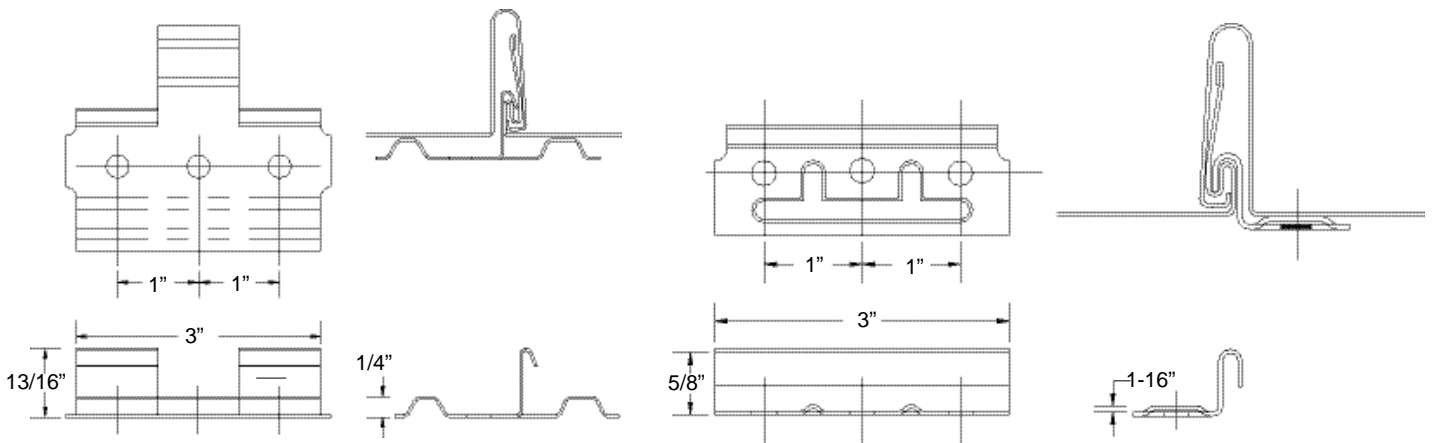

"RAISED" ANCHOR CLIPS
 MRS901 - 24 ga. G-90 galvanized steel
 MRS991 - 22 ga. stainless steel

NOTE: When utilizing the raised clip, all roof edge areas (ridges, valleys, eaves, gables, etc.) must be shimmed 1/4" so trim pieces are on the same plane as the panels. The raised clips allows for use of hex head type fasteners.

"FLAT" ANCHOR CLIPS
 MRS903 - 22 ga. stainless steel
 MRS904 - 24 ga. G-90 galvanized steel
 Clips designed for use with wafer (pancake) headed screws.

Eave Detail

1. In re-roofing applications: cut back and remove existing shingles and drip edge to be flush with the eave and gable lines, or as required to install underlayment.
2. In all applications: apply ATA-Shield** along eave and up the roof to a point at least 24" beyond outside face of exterior wall.
3. Install drip edge against fascia trim. Lay ATA-Guard* over eave trim.
4. Trim (cut) seam and water leg back to allow for turn down. Install panel by sliding lower flanged edge over drip edge.
5. Optional end closure is to pop-rievet cap in place as shown in sketch.

*General Note: Before any installation be sure to lay ATA-Shield** in all areas where ice & water can occur. ATA-Guard or appropriate underlayment should be installed over the entire roof. When asphalt based felt underlayment is used install a slip sheet, such as rosin paper, to minimize friction.*

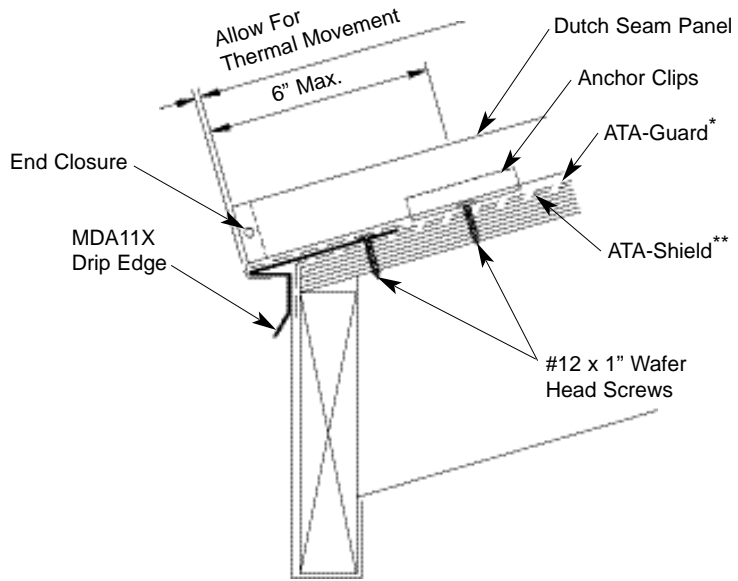

Gable Detail

1. At gable start detail, install gable trim starter cleat with appropriate fasteners at 2'-0" into fascia board.
2. At end gable, cut panel to appropriate width to allow room for clips at gable end. If panel cut off is 3" or wider install cut off portion of panel underneath last panel w/ butyl tape applied in between the two panels and install clips before installing gable assembly.
3. Apply double-faced butyl sealant as circled in sketch. Fasten "Z" closure to panel with pop-rivets.
4. Install starter cleat at end detail same as start detail.
5. At both ends snap gable/rake trim over starter cleat and "Z" closure to lock into place. Pop-rievet these two pieces together with one pop-rievet per trim length.

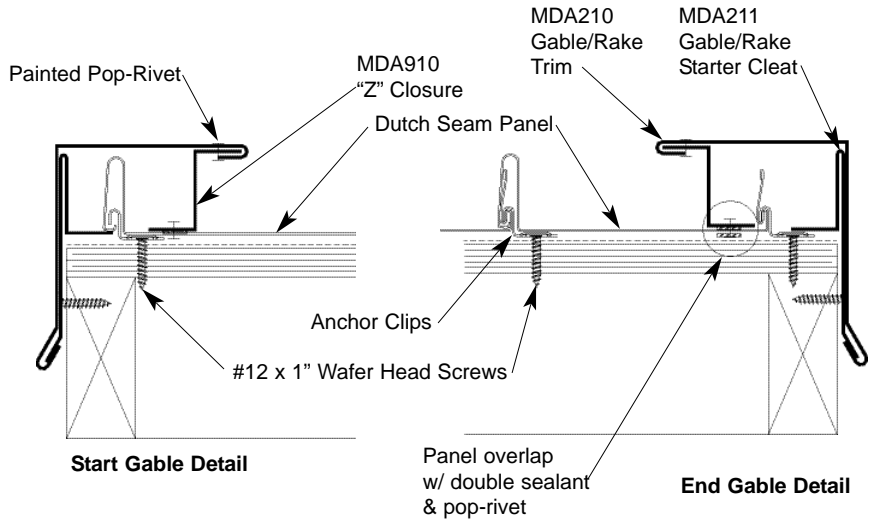

Valley Detail

1. Install ATA-Shield** approximately 18" up both sides of the valley line.
2. Lay valley pan in valley center. Locate joggle cleat at 4" to 6" from valley center.
3. Install joggle cleat. Fasten 6" o.c. through butyl tape and pan into substrate.
4. Turn under edge of panel to slide into joggle cleat. Fasten with clips at 2'-0" o.c.

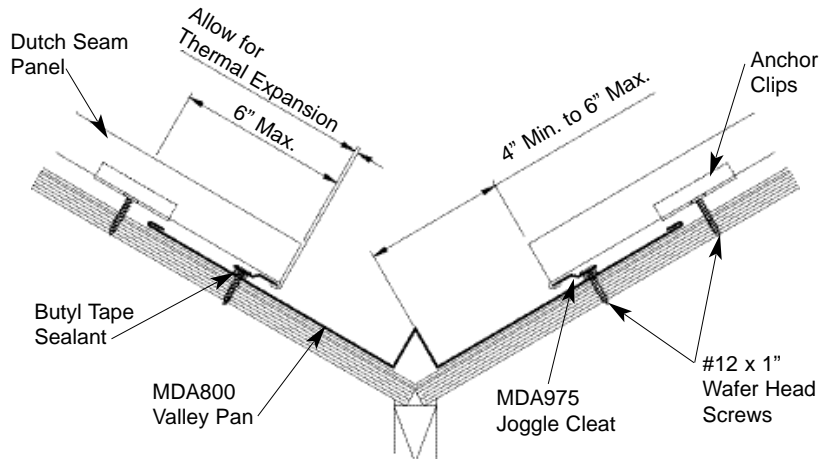

Underlayments: ATA-Guard* is a polyolefin based, 100% asphalt free, high strength reinforced roofing underlayment for use beneath metal roofing on steep slope applications. 1000 sq. ft. per roll at 48" wide.

Underlayments: ATA-Shield** is the recommended self adhesive underlayment for eaves, sidewall and any critical areas exposed to ice damming and extensive water run off. Available in 65'-8" x 39-3/8" rolls (2000 sq. ft. per roll).

Hip & Ridge Detail

Hip and ridge applications are handled in the same manner.

1. Cut "Z" closure to fit between seams and install in butyl tape. (Use 3 fasteners on 11" panel, 4 on 15", 5 on 19 1/4")

2. Seal neoprene strips into "Z" closures (formed neoprene for ridge; straight neoprene for hip).

3. Snap hip/ridge cap over "Z" closures for it to lock into place. Pop-rivet one side only to allow for expansion and contraction.

Notes:

* Trim must be pop-riveted to Z in at least one location to control thermal movement.

* Unless otherwise specified, all fasteners for trim components should be spaced at 2'-0" o.c.

* Install splice plates at ridge cap joints. Pop rivet splice to one end of ridge cap to allow for expansion and contraction.

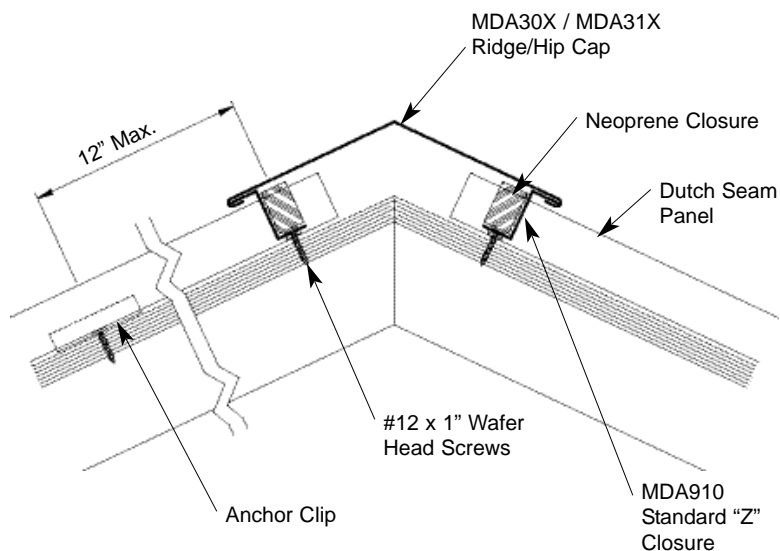

Headwall Detail

Install appropriate underlayment to the edge.

1. In standard headwall situation (without venting), run underlayment from roof plane up headwall. Install panels up to headwall.

2. Fasten "Z" closure in bed of sealant at top of panel. Seal formed neoprene closure into place in "Z" closure.

3. Install headwall transition over "Z" closure.

4. Apply counterflashing over the headwall trim, as required.

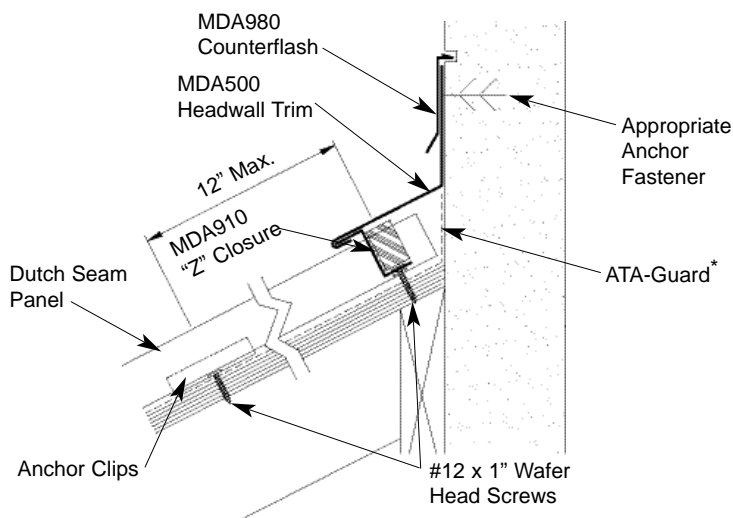

Shed Ridge Detail

1. Install metal panel up to the roof peak.

2. Fasten "Z" closure in bed of sealant at top of panel. Seal formed neoprene closure into place in "Z" closure.

3. Fasten starter cleat to face of trim boards at 2" below ridge line.

4. Install shed ridge cap trim over "Z" closure and starter cleat.

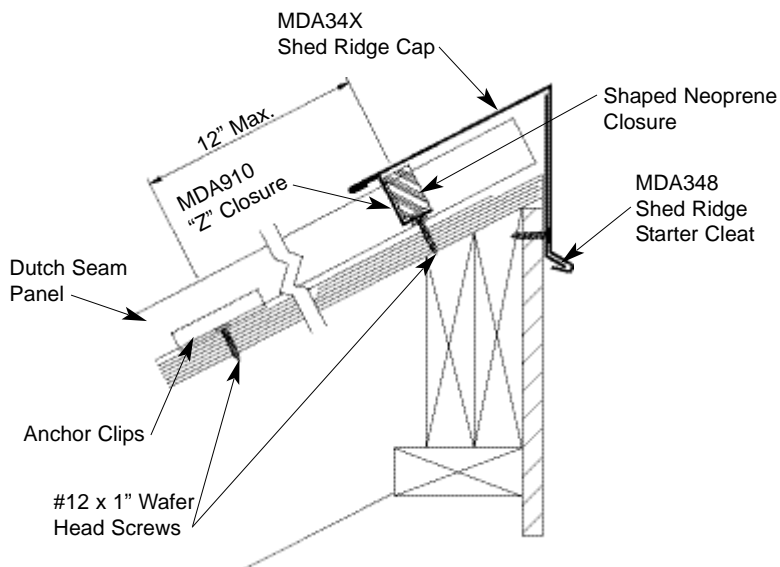

Sidewall Detail

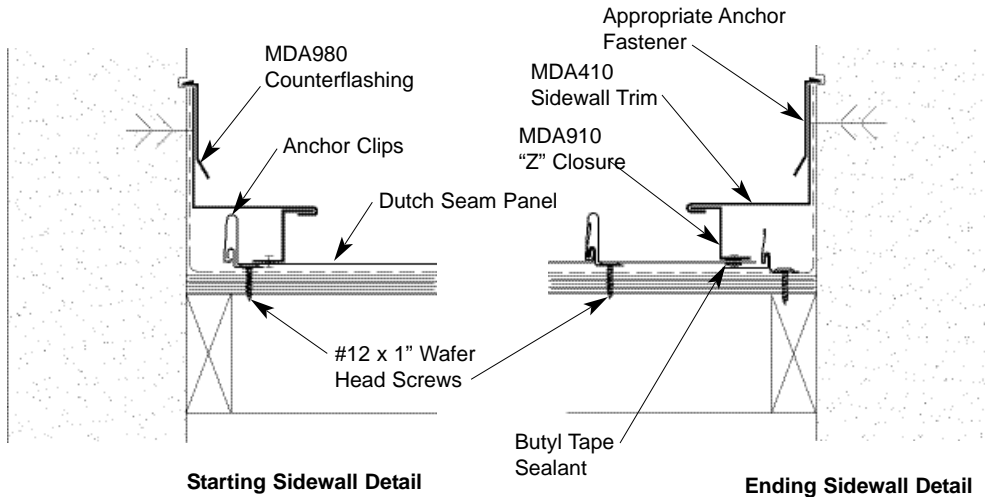

1. Install metal panel up to within 1" of the sidewall.

2. Fasten "Z" closure in bed of butyl sealant at top of panel as shown.

3. Fasten sidewall trim over "Z" closure to face of sidewall.

4. Apply counterflashing over the sidewall trim, and seal into reglet.

NOTE: Trims should be fastened to substrate and sidewall using a #12 x 1" wafer head screw.

Note Regarding Trim Details

The application of flashing and trim requires a detailed approach. Consideration should be given to the roof's geometry and course it creates for water run-off. Location of gutters and the use of snow retention systems should also be considered. Proper planning regarding the sequence of material overlap is critical. Sealants, such as butyl tapes and tripolymers, should be used at overlapping trim edges, in conjunction with exposed fasteners, and to seal flashings. All fasteners should be properly tightened and not overdriven at an angle. Fasteners that are too loose can "back out" over time. An overdriven fastener may cause a depression in the material, which becomes a collection point for standing water.

Pipe Detail

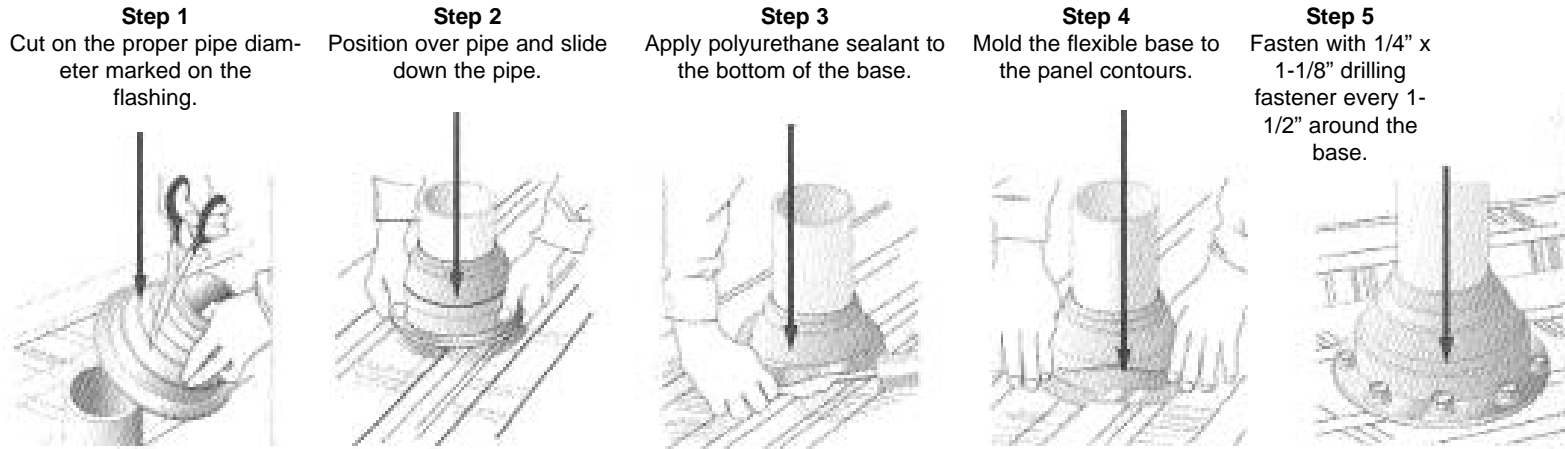

Pipe drawings provided by Triangle Fasteners

Tools and Rules:

Basic Equipment Required:

Tie-off ropes, safety harness, long level, ladders, scaffolding with approved planking, extension cords with approved ground plugs and services.

Additional Tools:

Metal folding tool, hammer, chalk line, measuring tape, metal cutting tools - nibblers, drills, hacksaw, utility knife, pop-rivet gun, caulking guns, layout and combination square, C clamps, sheet metal shears (including RH, LH, straight and overhand). Power driven screw gun with proper bits, depth-setting nosepiece, variable speed.

Choose the correct equipment and tools to do the job in a safe manner. Wear safety gear and follow OSHA requirements.

Follow of few simple rules:

1. Never cut the panels with an abrasive cut-off wheel or torch, as this will damage the finish.
2. Do not weld the trim or panels.
3. Remove any small burrs left by cutting, screwing or drilling.
4. Remove protective masking immediately after trim is installed.
5. Caution should be taken when unloading the panels to prevent damage.
6. Use appropriate screws for the type of underlayment and long enough to fully penetrate and secure the panel.
7. The stored materials should be kept dry.
8. Do not cut on finished roof. Remove all drill spirals, chips and dust immediately.
9. Seal neoprene closures and soft cell foam by applying appropriate sealant to both surfaces.
10. Put appropriate sealant/butyl tape between overlapping trims.
11. Overlap trims in a manner not to impede the flow of water.

For further information or assistance, contact our Residential Product Support at 877-286-3320